

LABORATORY COMBINATION REFRIGERATOR / FREEZER

LCRF 260 W xPRO (White finishing)

- **Structure:** upright type, realized in sheet steel epoxy coated white colour both in- and outside. The storage compartment is divided in the middle into 2 storage compartments fully insulated and completely independent between them, at the top the refrigerator compartment, while at the bottom the freezer. The internal corners of both the chambers are rounded to make easy any cleaning operations and the internal bottoms are tray type to contain spills
- **Insulation:** high density (40 Kg/m³) foamed-in-place polyurethane, with a thickness of 40 mm. CFC-free
- **Feet:** Nr 4, adjustable in height for levelling
- **Insulated door:** Nr 2, hinged, one above the other, both made with the same material and insulation as the rest of the structure (steel epoxy coated white colour always both in- and outside). The doors are provided with a removable magnetic rubber gasket in order to grant a perfect hermetic closing and reversibility facilities, to change the doors hanging. The handles are flush-fitting type so they do not increase the size of the cabinet. The doors are also fitted with a spring loaded automatic closing device for openings inferior 90°, a special door switch that stops the internal ventilation at the door opening (to limit the air cold loss) and lights the internal lighting at every opening. The freezer door (bottom) has an heated closing profile to prevent condensation or formation of frost
- **Internal equipment:** Nr 4 (2 for each door), storage open wire shelves realized sheet steel with a strong plastic coating (rust-proof material) . The shelves are mounted on special anti-tilt stainless steel slides that allows the shelf extraction and they can be easily removed and adjusted in height without the use of any tool. The special internal racking-system allows a great flexibility of the internal fitting with the possibility of interchange and combine both shelves and drawers (drawers optionally available)
 - Shelf dimensions (W x D cm) : 40 x 50
 - Shelf loading capability (Kg) : 25 (with uniformly stored material)
- **Internal lighting:** Nr 2 LED tubes (one for each compartment), mounted in the side wall of each chamber, with automatic activation both at every door opening and even through a touchpad on the control panel. They grant energy saving and prevent the internal heating produced by the traditional neon tubes
- **Control panels:** Nr 2, one for each compartment, both located in the top part of the structure (above each door). The control panels are both microprocessor operating with 6 soft-touchpads and LED display, allowing the control of all the functions and working status of the appliance (including alarms). The main functions of the control panels are :
 - LED display, with bright indication, red colour, of the actual internal temperature and enlightened icons in green colour indicating the appliance working status (compressor functioning, defrosting, fan running, etc.)
 - Digital temperature adjusting and displaying with an accuracy of 0,1°C
 - Keyboard buttons with locking protection, manually activable, to avoid tampering from unauthorized persons
 - Visual and acoustic alarm signalling (with automatic resetting) for:
 - high and low temperature with limits programmable from the user
 - door ajar, delayed to allow the standard operations
 - power failure (at the return of the mains supply)
 - anti-freezing evaporator
 - sensors failure
 - Muting facilities for the acoustic alarms with maintaining of the visual indication of the alarm condition
 - Alarms memory for the last 10 alarm conditions, with the possibility of checking from the display, the sort of alarm, when the alarm is started, when it is ended and which is the highest or lowest peak reached from the temperature (where applicable)

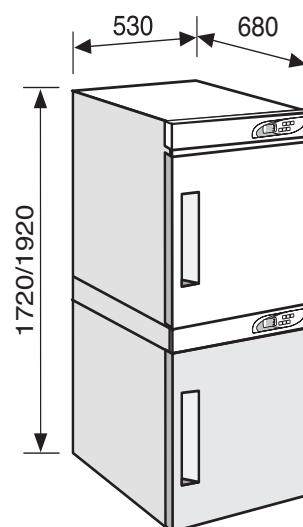

**LABORATORY COMBINATION
REFRIGERATOR / FREEZER**

- Ntc type sensors for a high accuracy of the temperature control
- NO/NC contact to remote the alarm signals
- **Cooling unit:** Nr 2, one for each compartment, both rear mounted, completely independent between them. Each condensing unit is compounded by Nr 1 hermetic compressor and Nr 1 finned condenser, air cooled through a fan. Also, in the ceiling of the storage chamber, is mounted the finned evaporator with copper pipes, that is housed into a stainless steel cover that incorporate the fan. All the mounted components are industrial grade to grant the maximum reliability
- **Refrigerant:** R134a CFC-free
- **Defrosting (both compartments):** completely automatic, thermostat controlled. The condensate water is automatically channelled into an heated tray, located in the motor compartment, for the automatic evaporation of the condensate water
- **Refrigeration (both compartments):** forced-air, through a fan, granting the maximum temperature uniformity and stability inside of the cabinet
- **Temperature range:**
 - REFRIGERATOR COMP. : adjustable between 0°C / +15°C
 - FREEZER COMP. : adjustable between -5°C / -20°C
- **Voltage (V/ph/Hz):** 220-230/1/50
- **Plug:** Nr. 2, one for each compartment, Schuko type
- **Breakers:** Nr 4 glass cartridge fuses with a rating of 10A, at protection of the appliance
- **Noise level (dB(A)):** ≤ 50
- **Gross capacity (litres):**
 - REFRIGERATOR COMP. : 150
 - FREEZER COMP. : 150
- **Net capacity (litres):**
 - REFRIGERATOR COMP. : 130
 - FREEZER COMP. : 130
- **Dimensions (W x D x H cm):** 53 x 68 x 192
- **Net weight (Kg):** 140
- **Packed dimensions (W x D x H cm):** 65 x 76 x 205 (1,01 m³)
- **Gross weight (Kg):** 160

LABORATORY COMBINATION REFRIGERATOR / FREEZER

ACCESSORIES AVAILABLE

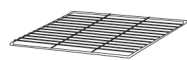

Extra wire shelf



Plastic partitions for drawers



Kit of rollers



Temperature chart recorder



Data logger function with USB port



Internal electrical socket

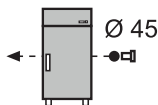

Cable port with cover Ø 45 mm

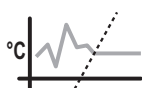

Temperature uniformity and stability kit

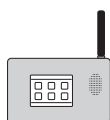

GSM/GPRS telephone dialer

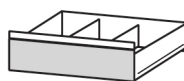

Stainless steel drawer

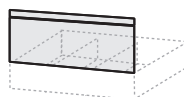

Front top for drawers



Safety door lock with key



Glass door



Ballasted sensor for simulation of product temperature alarm

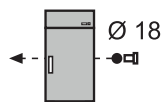

Cable port with cover Ø 18 mm



Safety anti-freezing thermostat



Natural refrigerant R290



230V / 60 Hz Different voltage



Wooden crate packing



115V / 60 Hz Different voltage



ISO 9001:2015



EN ISO 13485:2016



VERS. 03.19

* The declared performances are referred at +32°C ambient temperature, relative humidity of 70% and without any internal thermal mass (empty cabinet).

* Should it be necessary or useful without undermining any model essential features, technical and stylistic characteristics are subject to be changed without manufacturer's previous notice.